



Introduction

The Fault Tree Analysis, briefly FTA, was developed originally in the sixties in the area of the American telecommunication industry and aircraft industry. Only in the beginning of the eighties a formalization of these methods occurred at the instigation of American authorities.

The Fault Tree Analysis is used for reliability- and safety security analyses. The proceeding is very similar to the Reliability Block Diagram RBD.

The aim is to determine possible combinations of causes which can lead to certain undesirable events (event), the so-called top-level events.

Purpose and benefit

The goal is to identify possible combinations of causes that can lead to certain adverse events, the so-called top-level events. Furthermore, the task of an FTA is:

- The generation of a graphic / logical tree structure to the understanding of the connections.
- Identification of possible failure causes and their combinations.
- Calculation of the probability of the undesirable event. Comparison of variations.
- Comparison of variants

Basics

The link of the events is made in each case by different logical operators, the so-called gates. Device faults, operating faults and software faults which can cause with a certain probability to undesirable results belong to the events among other things.

The following symbolism is used to the representation of the fault tree:

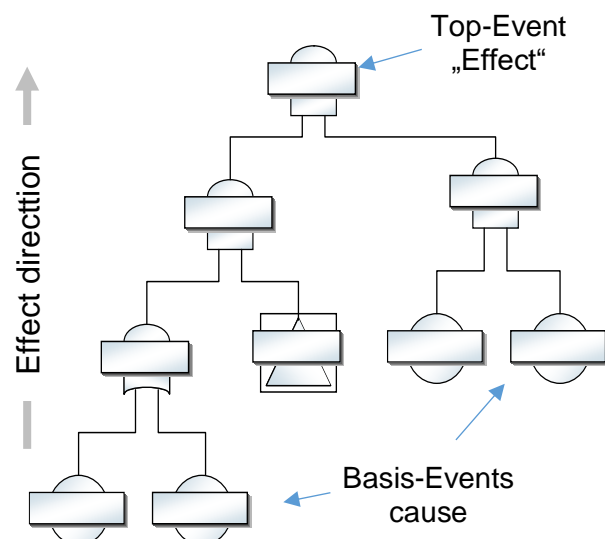

Symbolic

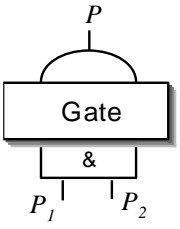
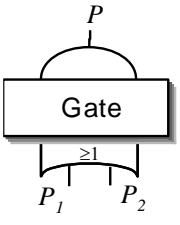
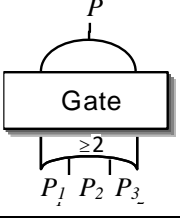
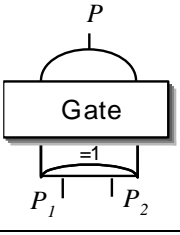
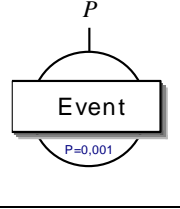
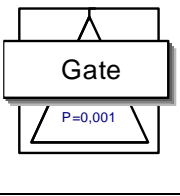
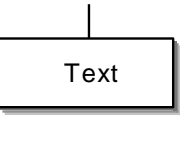
	<p>&</p>	<p>AND-Gate The output event enters only if all input events apply. The output probability P is calculated with:</p>
	<p>≥1</p>	<p>OR-Gate The output event enters if one of the input events applies. The output probability P is calculated with:</p>
	<p>≥2</p>	<p>Vote-Gate The output event occurs when at least two input events occur. At least 3 inputs are required for this.</p>
	<p>=1</p>	<p>XOR-Gate (Exclusive-OR) The output event enters if only one of the input events apply but not both. The output probability P is calculated with:</p>
		<p>Basic-Event Primary base event or failure. The probability P is defined directly and mostly comes from manufacturer's data of the component. As with the reliability block diagram P is dependent on the time (component age).</p>
		<p>Sub-Gate At this point the other representation is interrupted. The given probability P represents the summary of other sub-elements which are not shown further.</p>
		<p>Neutral text element Text elements can be inserted in paths to show additional information, or to insert other "creases". At several entrances this element works like an OR gate.</p>

Hint: The symbolism is according to country and standards, as well as in software partly differently.

The exit from P can be negated (example on the left). Then P describes the probability that the event does not enter. This is marked by a symbol of a circle at the entrance of the following gate.

The input probability of the following gate is: $P_I = 1 - P$.

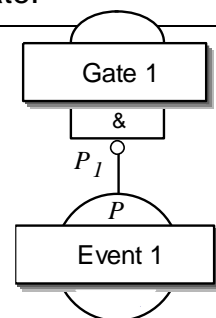

The advantage of the FTA is the hierarchical tree structure. In the upper area you can find the basic connections in the coarser area, in the lower area you can find the details. The FTA thus also provides good documentation of the relationships, even if the probabilities are not specified (qualitative fault tree).

There must be no opposing influences in the FTA, the elements must be independent of one another.

The fault tree starts at the top with the Top Event. At the bottom, the event paths are broken down further and further until one arrives at the Basic Events, or at the Sub-Gates, for which the further details are not detailed.

The following example shows a fault tree with calculated probabilities

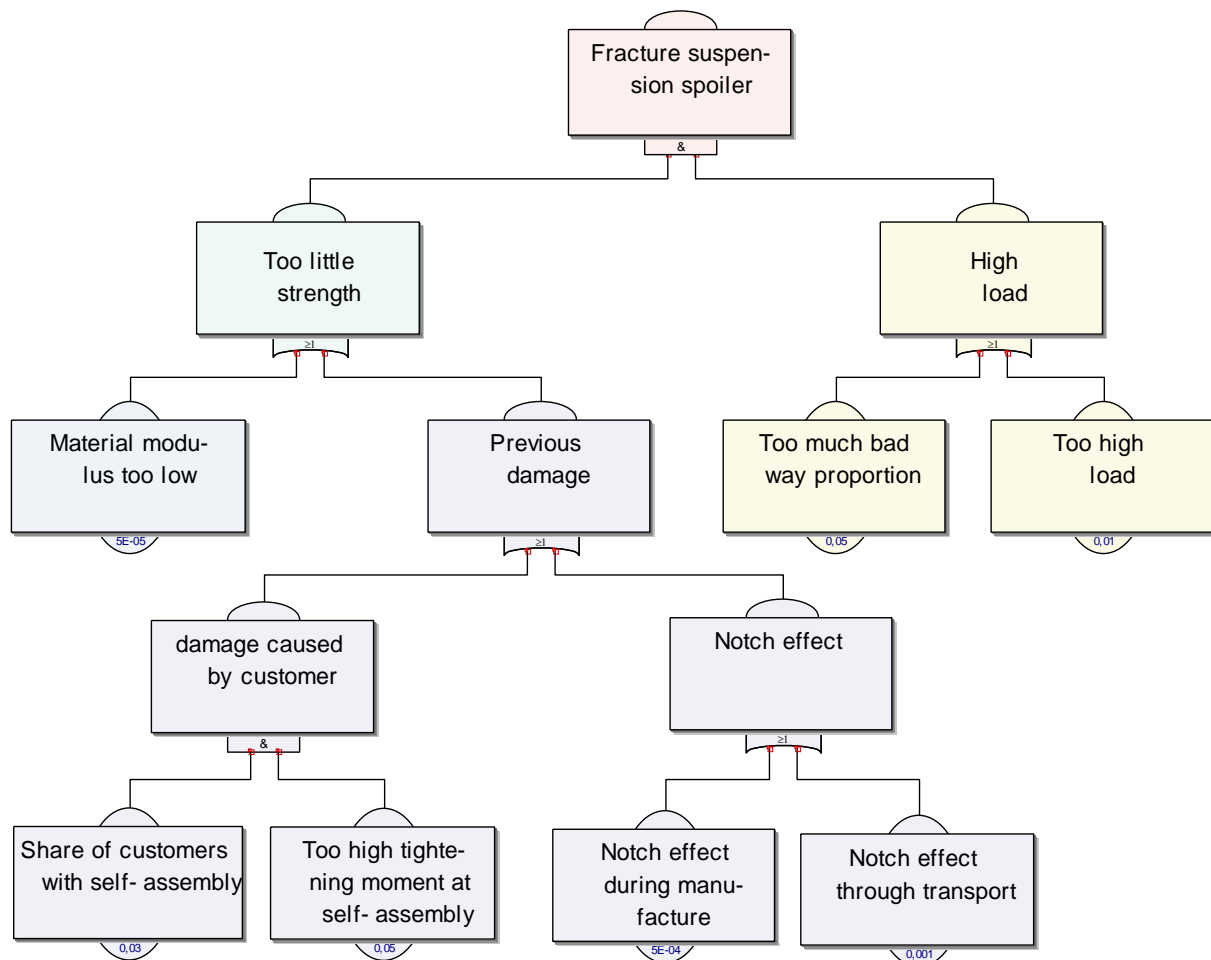

In this example, the system is initially divided into its properties (strength) and what it experiences (load). This is followed by the relevant connections and, at the end, the actual causes (basic events).

In addition to the example shown, the FTA is particularly suitable for the electrical / electronic area or for control and regulation systems. The FTA is not the right tool for just looking at software.

In the comparison no probability is treated moreover in a causes-effect diagram. One looks only at the "critical" moment when the fault occurs as a top event.

Calculating the gates

In the following overview mean

P = Probability of failure; **R** = Reliability = 1 – P; **E** = (error) event.

The event at the output only applies if there is a 1 in the last column. The corresponding probability for this is the sum of the product probabilities (disjunctive normal form).

Sample values for $P_1 = 0.01$; $P_2 = 0.02$; $P_3 = 0.03$

<p>And-Gate (&)</p>	<table border="1"> <thead> <tr> <th>E₁</th> <th>E₂</th> <th>E₃</th> <th>E</th> </tr> </thead> <tbody> <tr><td>0</td><td>0</td><td>0</td><td>0</td></tr> <tr><td>1</td><td>0</td><td>0</td><td>0</td></tr> <tr><td>0</td><td>1</td><td>0</td><td>0</td></tr> <tr><td>0</td><td>0</td><td>1</td><td>0</td></tr> <tr><td>1</td><td>1</td><td>0</td><td>0</td></tr> <tr><td>0</td><td>1</td><td>1</td><td>0</td></tr> <tr><td>1</td><td>0</td><td>1</td><td>0</td></tr> <tr><td>1</td><td>1</td><td>1</td><td>1</td></tr> </tbody> </table>	E ₁	E ₂	E ₃	E	0	0	0	0	1	0	0	0	0	1	0	0	0	0	1	0	1	1	0	0	0	1	1	0	1	0	1	0	1	1	1	1	$P_1 \cdot P_2 \cdot P_3$	$P = P_1 \cdot P_2 \cdot P_3$ $= 0.01 \cdot 0.02 \cdot 0.03 = 6E-6$
E ₁	E ₂	E ₃	E																																				
0	0	0	0																																				
1	0	0	0																																				
0	1	0	0																																				
0	0	1	0																																				
1	1	0	0																																				
0	1	1	0																																				
1	0	1	0																																				
1	1	1	1																																				
<p>OR-Gate (≥1)</p>	<table border="1"> <thead> <tr> <th>E₁</th> <th>E₂</th> <th>E₃</th> <th>E</th> </tr> </thead> <tbody> <tr><td>0</td><td>0</td><td>0</td><td>0</td></tr> <tr><td>1</td><td>0</td><td>0</td><td>1</td></tr> <tr><td>0</td><td>1</td><td>0</td><td>1</td></tr> <tr><td>0</td><td>0</td><td>1</td><td>1</td></tr> <tr><td>1</td><td>1</td><td>0</td><td>1</td></tr> <tr><td>0</td><td>1</td><td>1</td><td>1</td></tr> <tr><td>1</td><td>0</td><td>1</td><td>1</td></tr> <tr><td>1</td><td>1</td><td>1</td><td>1</td></tr> </tbody> </table>	E ₁	E ₂	E ₃	E	0	0	0	0	1	0	0	1	0	1	0	1	0	0	1	1	1	1	0	1	0	1	1	1	1	0	1	1	1	1	1	1	$P_1 \cdot R_2 \cdot R_3 +$ $R_1 \cdot P_2 \cdot R_3 +$ $R_1 \cdot R_2 \cdot P_3 +$ $P_1 \cdot P_2 \cdot R_3 +$ $R_1 \cdot P_2 \cdot P_3 +$ $P_1 \cdot R_2 \cdot P_3 +$ $P_1 \cdot P_2 \cdot P_3 =$	$P = 1 - R_1 \cdot R_2 \cdot R_3$ $= 1 - (1 - P_1) \cdot (1 - P_2) \cdot (1 - P_3)$ $= 1 - 0.99 \cdot 0.98 \cdot 0.97 = 0.0589$ <p>where for very small P and the resulting even smaller products</p> $P \approx P_1 + P_2 + P_3$ $\approx 0.01 + 0.02 + 0.03 = 0.06 > 0.0589$
E ₁	E ₂	E ₃	E																																				
0	0	0	0																																				
1	0	0	1																																				
0	1	0	1																																				
0	0	1	1																																				
1	1	0	1																																				
0	1	1	1																																				
1	0	1	1																																				
1	1	1	1																																				
<p>Vote-Gate (≥2)</p>	<table border="1"> <thead> <tr> <th>E₁</th> <th>E₂</th> <th>E₃</th> <th>E</th> </tr> </thead> <tbody> <tr><td>0</td><td>0</td><td>0</td><td>0</td></tr> <tr><td>1</td><td>0</td><td>0</td><td>0</td></tr> <tr><td>0</td><td>1</td><td>0</td><td>0</td></tr> <tr><td>0</td><td>0</td><td>1</td><td>0</td></tr> <tr><td>1</td><td>1</td><td>0</td><td>1</td></tr> <tr><td>0</td><td>1</td><td>1</td><td>1</td></tr> <tr><td>1</td><td>0</td><td>1</td><td>1</td></tr> <tr><td>1</td><td>1</td><td>1</td><td>1</td></tr> </tbody> </table>	E ₁	E ₂	E ₃	E	0	0	0	0	1	0	0	0	0	1	0	0	0	0	1	0	1	1	0	1	0	1	1	1	1	0	1	1	1	1	1	1	$P_1 \cdot P_2 \cdot R_3 +$ $R_1 \cdot P_2 \cdot P_3 +$ $P_1 \cdot R_2 \cdot P_3 +$ $P_1 \cdot P_2 \cdot P_3 =$	$P = P_1 \cdot P_2 + P_2 \cdot P_3 + P_1 \cdot P_3 -$ $- P_1 \cdot P_2 \cdot P_3 - P_1 \cdot P_3 \cdot P_2 - P_2 \cdot P_1 \cdot P_3$ $+ P_1 \cdot P_2 \cdot P_3$ $= 0.01 \cdot 0.02 + 0.02 \cdot 0.03 + 0.01 \cdot 0.03$ $- 0.01 \cdot 0.02 \cdot 0.03 - 0.01 \cdot 0.03 \cdot 0.02$ $- 0.02 \cdot 0.01 \cdot 0.03$ $+ 0.01 \cdot 0.02 \cdot 0.03$ $= 0.001088$
E ₁	E ₂	E ₃	E																																				
0	0	0	0																																				
1	0	0	0																																				
0	1	0	0																																				
0	0	1	0																																				
1	1	0	1																																				
0	1	1	1																																				
1	0	1	1																																				
1	1	1	1																																				
<p>XOR-Gate (=1)</p>	<table border="1"> <thead> <tr> <th>E₁</th> <th>E₂</th> <th>E₃</th> <th>E</th> </tr> </thead> <tbody> <tr><td>0</td><td>0</td><td>0</td><td>0</td></tr> <tr><td>1</td><td>0</td><td>0</td><td>1</td></tr> <tr><td>0</td><td>1</td><td>0</td><td>1</td></tr> <tr><td>0</td><td>0</td><td>1</td><td>1</td></tr> <tr><td>1</td><td>1</td><td>0</td><td>0</td></tr> <tr><td>0</td><td>1</td><td>1</td><td>0</td></tr> <tr><td>1</td><td>0</td><td>1</td><td>0</td></tr> <tr><td>1</td><td>1</td><td>1</td><td>0</td></tr> </tbody> </table>	E ₁	E ₂	E ₃	E	0	0	0	0	1	0	0	1	0	1	0	1	0	0	1	1	1	1	0	0	0	1	1	0	1	0	1	0	1	1	1	0	$P_1 \cdot R_2 \cdot R_3 +$ $R_1 \cdot P_2 \cdot R_3 +$ $R_1 \cdot R_2 \cdot P_3 =$	$P = P_1 \cdot (1 - P_2) \cdot (1 - P_3) +$ $(1 - P_1) \cdot P_2 \cdot (1 - P_3) +$ $(1 - P_1) \cdot (1 - P_2) \cdot P_3$ $= 0.01 \cdot 0.98 \cdot 0.97$ $+ 0.99 \cdot 0.02 \cdot 0.97$ $+ 0.99 \cdot 0.98 \cdot 0.03$ $= 0.0578 < P(\text{OR}) = 0.0589$
E ₁	E ₂	E ₃	E																																				
0	0	0	0																																				
1	0	0	1																																				
0	1	0	1																																				
0	0	1	1																																				
1	1	0	0																																				
0	1	1	0																																				
1	0	1	0																																				
1	1	1	0																																				

Calculation via so called Cut Set

If Basic Events or Sub-Gates have an influence on several gates, a calculation starting from the base event will give incorrect results for the top event. The following example shows such a situation in which event E3 has an influence both in gate C and in gate D (e.g. a temperature could affect several paths):

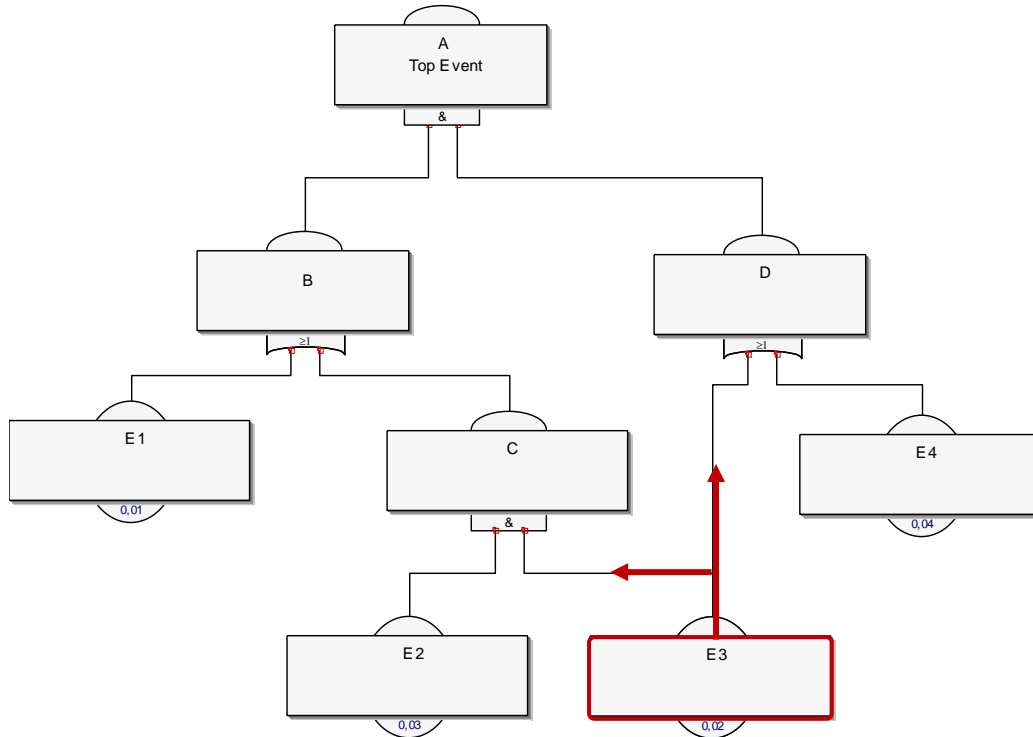

The calculation according to the algorithm of J.B. Fussell takes place step by step in tabular form until only Basic Events or Sub-Gates remain.

The complete production of the fault tree assumes that one can name all components and conditions. This is not always given under circumstances if, e.g., a failure appears as only temporary and is not known what condition must be still given here. This can be avoided first by a "place holder" who is to be determined later

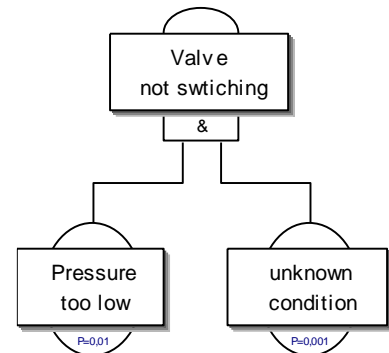

Comparison with a Reliability-Block-Diagram (RBD)

As at the beginning described, the comparison with the reliability block diagram should be still shown (Reliability-block diagram = RBD).

Conspicuously is that here no gates are shown, but only the suitable components which are the base events in the FTA.

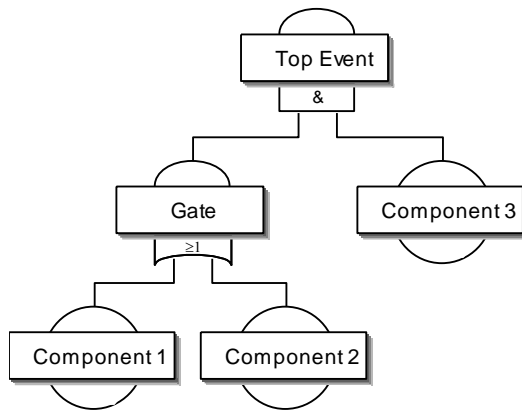

Fault - Tree

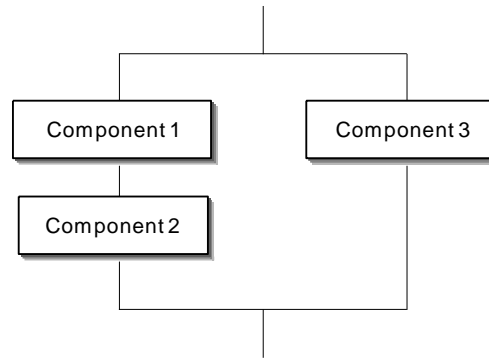

Reliability Block Diagram

While in the FTA a redundancy is shown merely as AND link, this seems more striking in the RBD by the parallel arrangement. The difference between OR / AND link is stronger emphasised here graphically. The advantage is also that here less elements are needed. However, the disadvantage of the RBD is that none Exclusive OR-links are possible.

With the treatment of a problem, the comparison with a cause-effect-diagram is also looked often. If there are "conditions" or components which are not known yet, exists in the FTA the problem to name this. Here as a rule one places pseudo-elements which are to be determined even closer. In the cause-effect-diagram one is led there about the physical / technical active chain rather on the still missing connections. Further details to active diagram are described under:

www.weibull.de/COM/Systemanalysis.pdf.

Using Visual-XSel

The fault tree analysis is provided in Visual-XSel purely graphically. Click to the icon in the main guide...

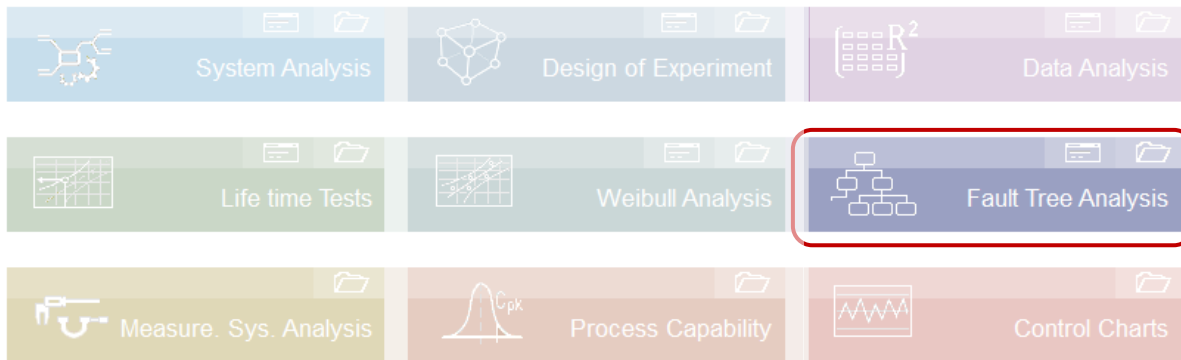

or via the icon *Analyses*

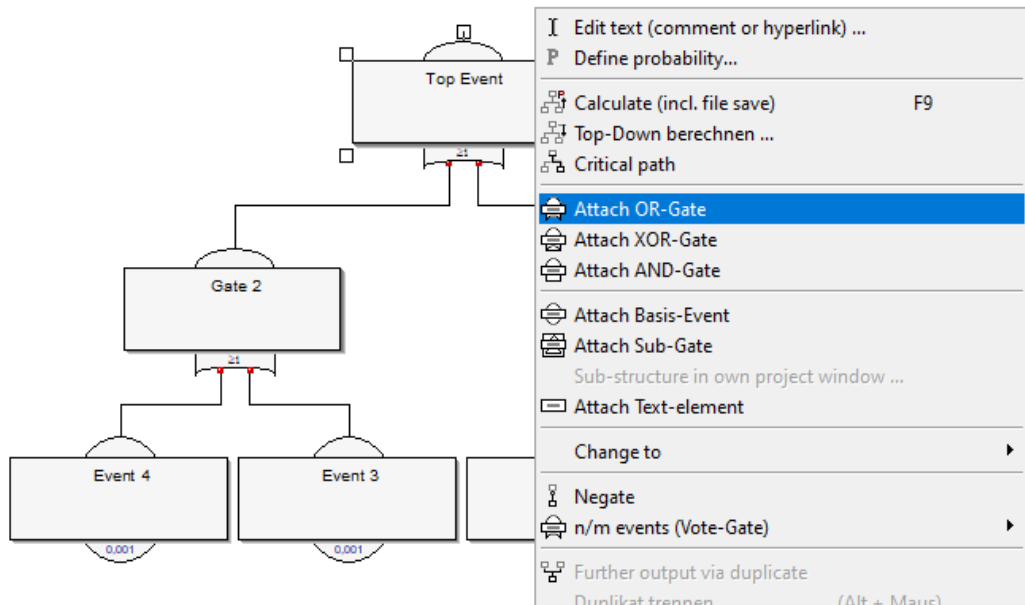
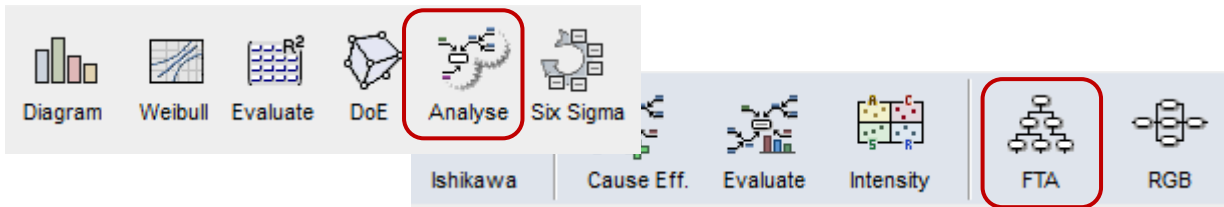

A basis tree appears. Click to an element and use the right mouse button, for example to add a new Gate.

Arrange elements

The default setting is that new elements are arranged automatically. Alternatively, the gates can be manually positioned like free drawing elements. In this case the Auto arrange function will be switched off.

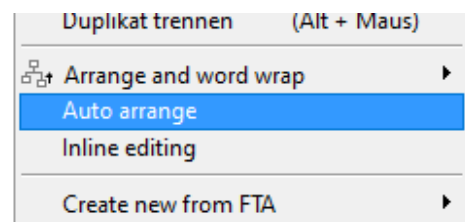

If the **Alt-key** is optionally held down when moving elements, all elements below are not taken along. This concern also to double gates which lie on top of each other. This makes it possible to separate them again. Without the **Alt-key**, all elements with an input are dragged into the clicked element. His own output-connection at the top remains in its original position (left picture). If you go with the mouse on the output connection, the reference upwards is separated (right picture).

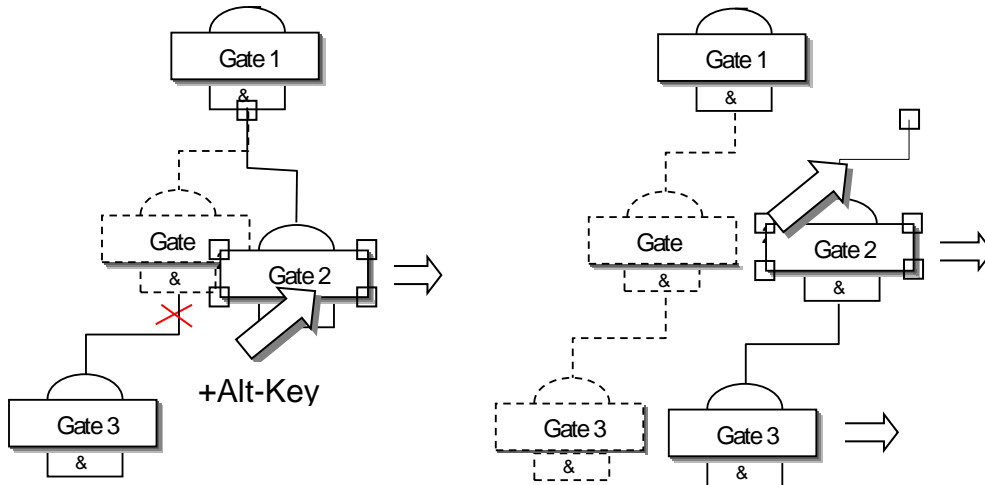

In case of printing it can happen that the paper size is not suitable. The border of the paper is shown in the main-window with a grey dotted line. Please use **Options/Format and Frames** and an adequate paper size. Normally the structure is overstepping the right border. Instead of printing side by side below each other, it will be used side by side to the right automatically. So the paper size must only inside the bottom limit.

Edit text

With the choice of the titles in the gates and events one should use a very clearly and exact description. However, because of less space it is not practicable to use too long text. Therefore, it is possible for a detailed description in an element to define hidden text. This not visible text becomes in the edit mode (double click or right mouse key) by the pipe sign | marked.

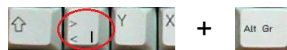

← Behind pipe | text will be hidden

after end of text mode
(double click outside text)



If the option *Inline editing* is not set, the text can be entered via a dialog box. Here the visible title, the commentary and a possible link can be edited in separate fields.

Alternatively the probability can be defined here directly.

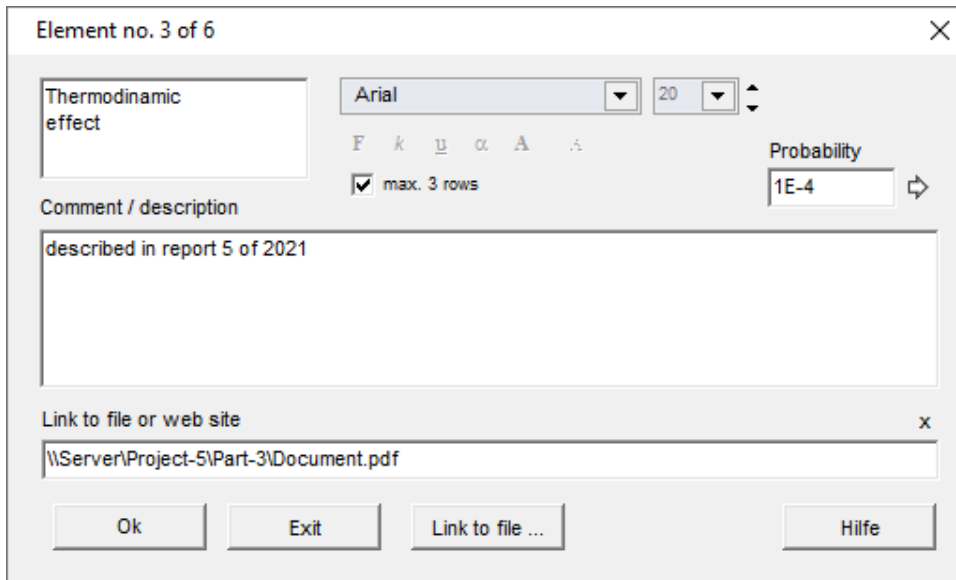
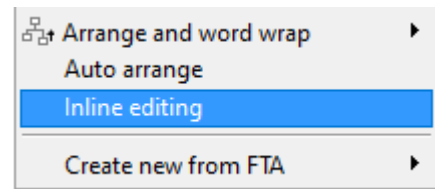

Important: The text length in the elements is initially not limited. When using the automatic arrangement, a structure is created in the table after each change, which can only use 256 characters in a cell. If longer text lengths are required, the automatic arrangement must therefore be switched off.

Probability of occurrence for Basic-Events and Sub-Gates

For the Basis Event and the Sub Gate the probability can be defined. The option to define the probabilities directly is based on the common classification that is also used in the FMEA. As a guide, the associated rating number for occurrence A from 2 to 10 is also shown. The table in Visual-XSel 16.0 has been supplemented for version 15.0 by the new table from the FMEA manual according to AIAG / VDA as of 2019. It should be noted here that the values have changed (e.g., 1 ppm is now A = 2 instead of A = 1).

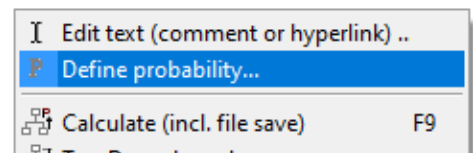

Other values can be defined in the middle. When using statistical distributions, the most commonly used is the exponential distribution with the failure rate λ . The time is to be understood in hours. Different "operating hours" can be assigned to different elements. This is useful, for example, if certain components in a system have been in function for different lengths of time and are therefore subject to different calendars. With the Weibull distribution, different failure characteristics can be mapped (via definition of b). With t_0 it is also possible that a component has a failure free time in which the element remains intact.

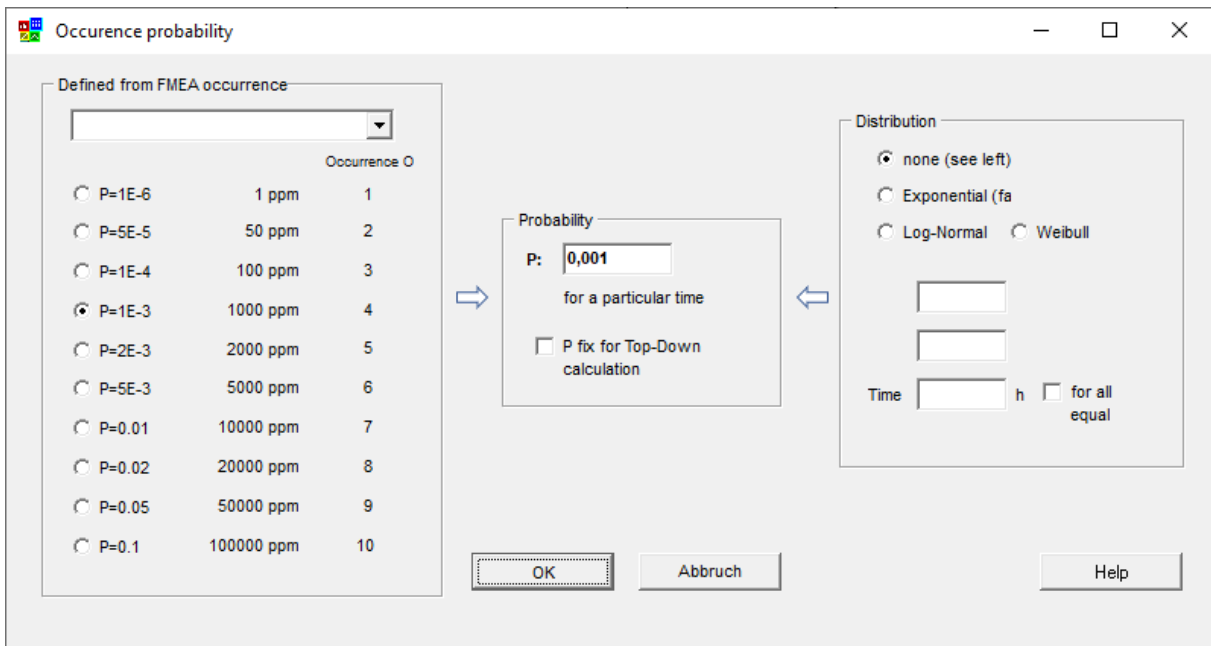

If the same operating time applies to all components, the option "**for all equal**" must be set. All elements in the fault tree then receive the time of the currently selected value.

Once all the probabilities of occurrence have been determined, the probability of the "top event" occurring can be calculated (Calculate pop-up menu with the right mouse button), or press F9.

Calculation of the probability of the Top-Event

In Visual-XSel there are two different calculation methods, the direct bottom-up calculation and the calculation using a tabular cut set. The latter is only used if there are duplicates (base event has an effect on more than one gate).

With the bottom-up calculation, the next higher gates are calculated, starting with the base events or sub-gates, until the top event has been reached. Since there are no intermediate results for the gates in the cut set calculation in the table, no probabilities of the gates are displayed here.

Top-Down calculation

There is the possibility of the opposite calculation by specifying a maximum permissible probability of the top event. The occurrence probabilities for the base events and sub-gates are determined iteratively. This can be used to calculate backwards what the parts and components may have for a maximum failure probability. If, however, the probability of failure of some of the components is known, this can be preset and the iterative calculation varies only the remaining components.

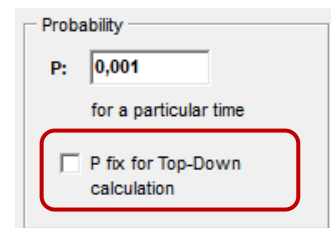

Critical Path

If you want to know which "path" has the greatest influence on the top event, you can do this graphically using the menu item Critical Path (pop-up menu right

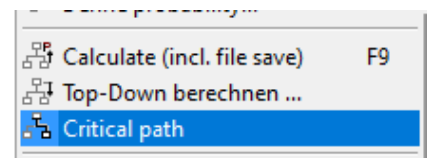

mouse button) using the line thickness of the connections represent. If there are the same probabilities in a partial structure, no marking is made.

Important: In the case of duplicates (the basic event is spread over several gates), the calculation is made using minimal cuts. The calculation of the intermediate results in the gates is not possible here, so that no continuous critical path can be displayed.

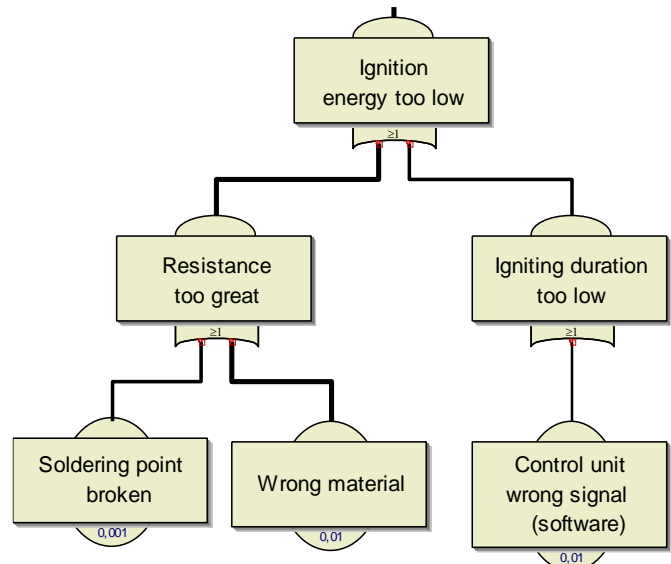

Duplicates (multiple outputs)

As described in the chapter Calculation using minimal cuts, base events and gates can be linked to several gates. This is made possible in Visual-XSel via duplicates. I.e. an element is placed as a duplicate over an existing one. For example, E3 should have a second output to Gate C:

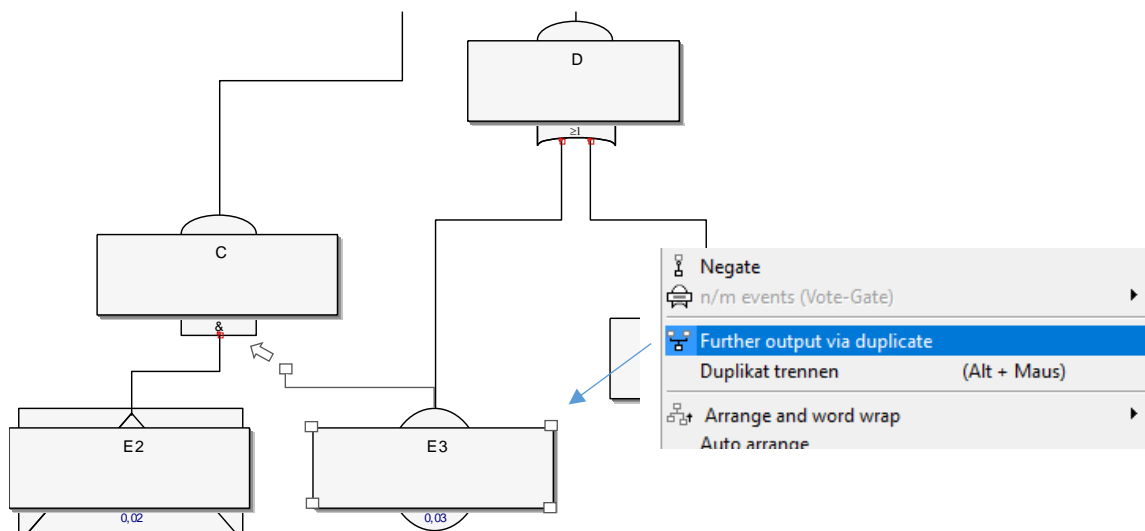

Click on E3 and use the right mouse button to select Further output via duplicate. Text and probability are taken from the original. Move the tip of the output to the desired gate, here C.

If duplicates are chosen, the top event is calculated using minimum cuts (cut set).

If the text is changed, the original always has the same content. The elements can be separated again with the mouse and the pressed Alt key or with the corresponding menu item.

Division of the sub-gates into further substructures

In the case of a very extensive fault tree, it makes sense to split it up. The sub-gate element already makes it clear that there are more detailed relationships that normally should not be shown in more detail. From version 16.0 it is possible to create an advanced FTA for this and thus complex systems split up. Click on the desired sub-gate and right-click to select a sub-gate as a substructure.

A new project window with the basic structure opens, whereby the title of the top event is taken over from the previous sub-gate.

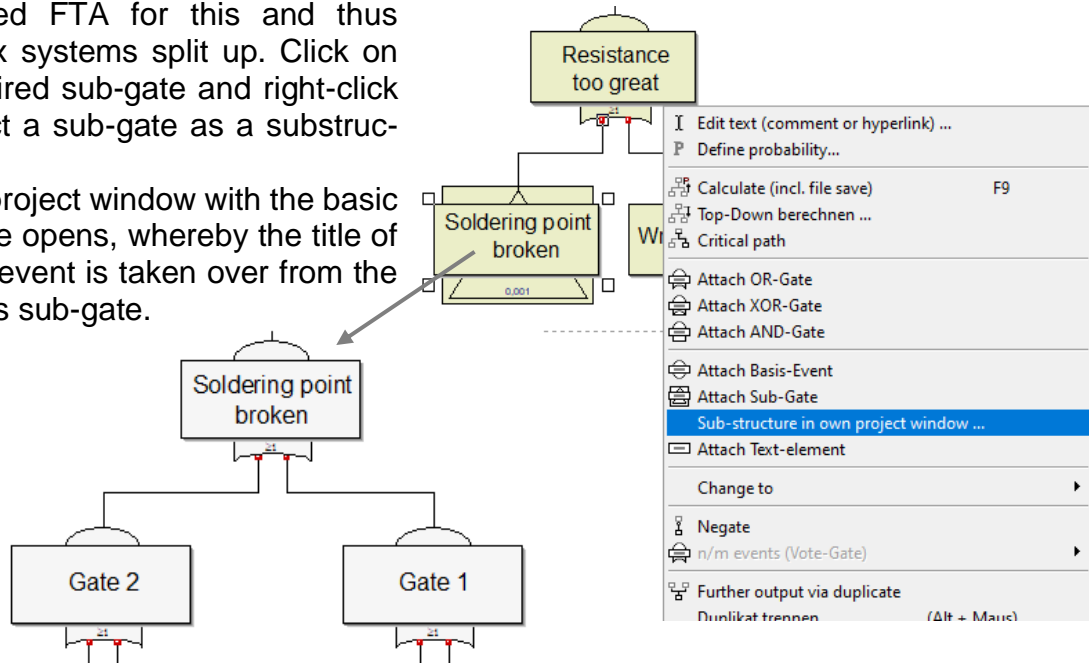

After processing and calculation, you can switch back to the original FTA via the left menu item Project / Main project. The calculated probability of the top event from the substructure is now used here as input.

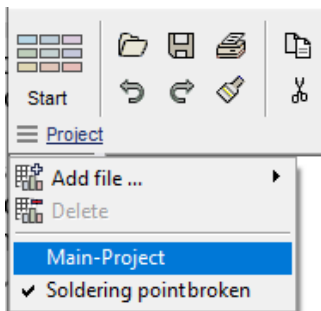

The creation of a substructure is only possible from the main project, as is the described transfer of the probability. If one nevertheless wishes to describe further sub-gates at deeper "levels" in a substructure, the calculated probability must be transmitted manually. I.e. reading the probability in the top event and in the higher FTA entry via the menu item Define probability (right mouse button on the sub-gate).

Export a FTA to a FMEA

The elements of the FTA can be exported in a list or a FEMA-form. For this click of an arbitrary element, and use the last choice of the pop-up menu (right mouse button).

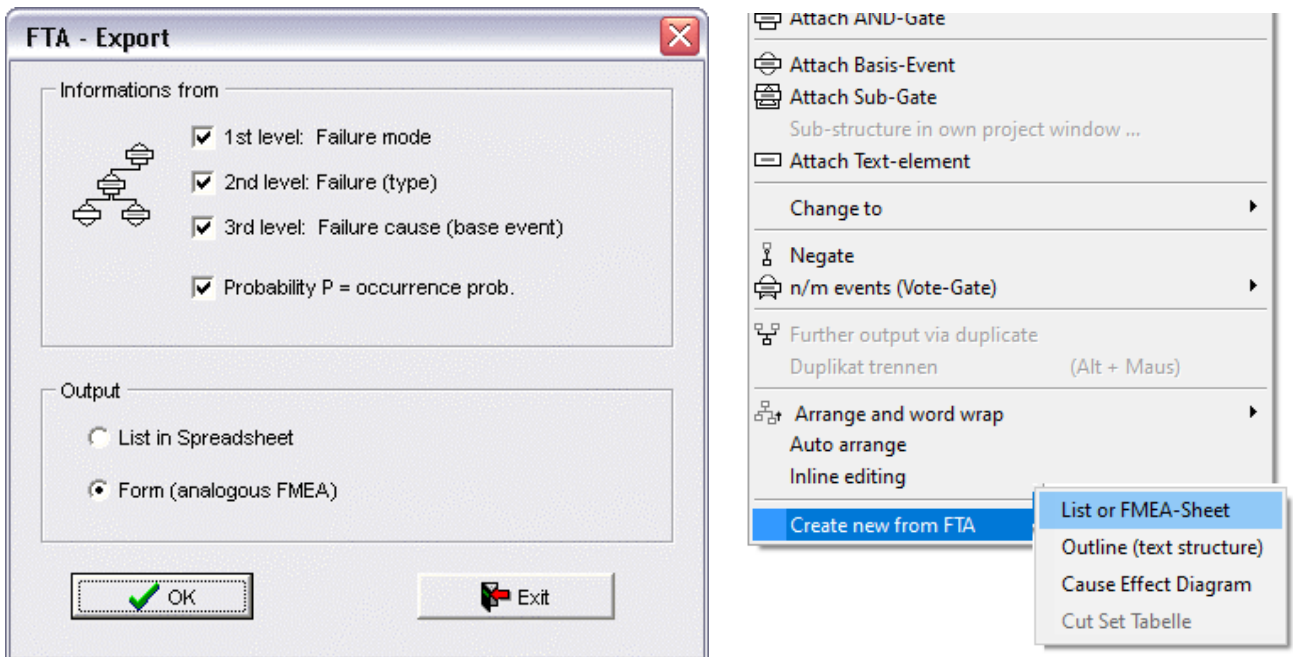

Normally a FTA is derived from a FMEA. The shown function is a backward method. What is the advantage? At the beginning the graphically (FTA) overview is more understandable and clearer, compared with a list of items. With this event-based system analysis a good understanding can be approached very fast. For the export the FTA should be arranged in 3 levels. The top level, normally the top event, defines here the system. This makes sense for building up a system FTA. If using only a top event, the output is only a part of a complete product/system.

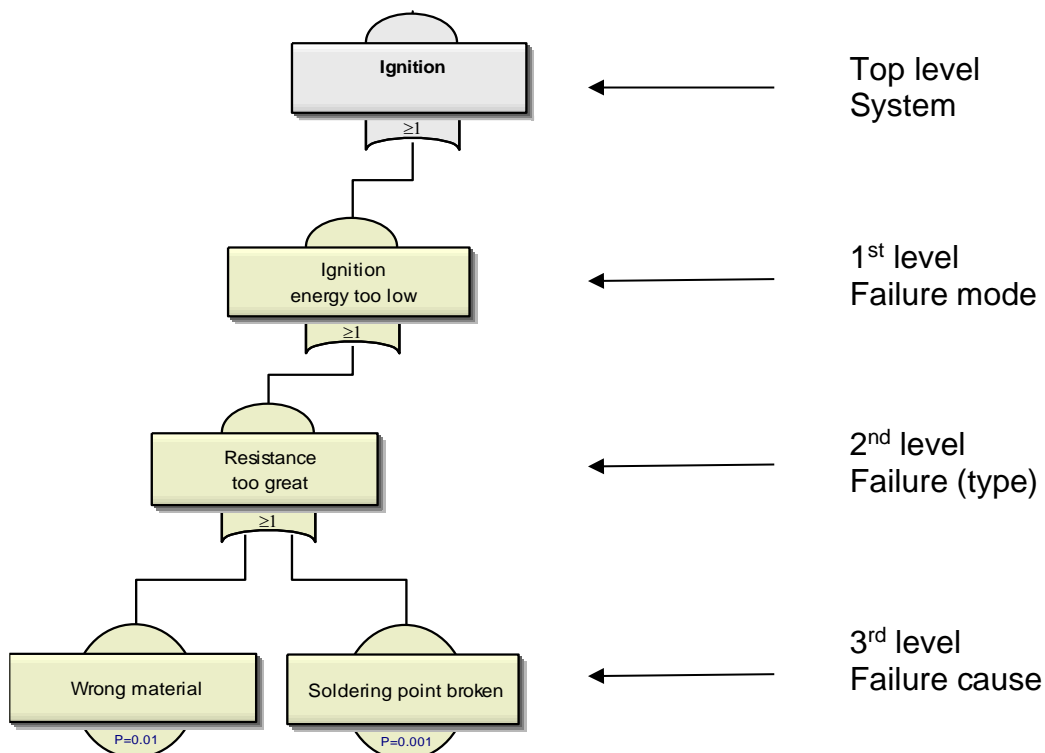

Below of the system the failure mode, the failure type and the failure cause are following. Between the system and the first level more structures (elements) can be defined, but these elements have no input in the Form. The defined probability P of the basic- or sub-gate event can be used optional as an occurrence probability (risk). This confirms also to an assessment-value.

	A	B	C	D	E	F	G	H	I	
1	Project:					FMEA: Form				
2										
3	System:					Process-FMEA		Product-FMEA		
4										
5						Name / departure			Name of Process- / Product:	
6										
7										
8						S-Severity			C-Attribute	
9									O-Occurrence probability	
10		Failure mode	S	Failure	C	Failure cause	Avoidance action	O	Detection action	
11	1	Ignition fault		Combustion chamber bad condition		Mixture temperature too high or wrong		4		
12										
13	2	Ignition fault		Combustion chamber bad condition		Mixture too lean. Adaption inaccurate		4		
14	3	Ignition fault		Spark plug not optimal		Spark plug gap too big		4		
15	4	Ignition fault		Spark plug not optimal		Electrode too deeply screwed		4		
16	5	Ignition energy too low		Igniting duration too low		Control unit wrong signal (software)		7		
17	6	Ignition energy too low		Resistance too great		Wrong material		7		
18	7	Ignition energy too low		Resistance too great		Soldering point broken		4		
19										
20										

All other fields in the FMEA-form must be filled in the table. If there are changes in the FTA a new table will be created the present entries are preserved. To combine the existing definitions with the new table, use copy and paste.

To learn about basics of the FMEA and getting continuing information here must be refer to the appropriate literature.

In Visual-XSel there can be build up a FTA and a cause-effect-diagram in the same file. This makes it possible to have different perspectives and to get specifically advantages of both methods. For more information to the cause-effect-diagram see www.weibull.de/COM/Systemanalysis.pdf

An alternative to the FTA is the Reliability-Block diagram which is defined in an own window (see menu Data/ Reliability-Block diagram).